



CFX-9850GB PLUS
CFX-9950GB PLUS
Software Library





Acknowledgement

We would like to thank all of the
professors and teachers around
the world without whose programs this
Software Library
would not be possible.

CASIO COMPUTER CO., LTD.

Loading Program Library Programs

This calculator comes with a built-in Program Library that provides you with a collection of application programs. Unlike programs you input yourself, you must use the procedure described below to load Program Library programs into memory before you can run them.

- The Program Library is divided into sub-libraries.
- You cannot edit or reference the contents of a Program Library program.

To load the program “FACT” (JAPAN sub-library)

1. On the icon menu, select **PRGM**.



2. Use the function keys to execute the LOAD command.

F6 (▷) **F5** (LOAD)



3. Use the **▲** and **▼** cursor keys and **EXE** to select first the sub-library and then the program.

(**▼**) (**▼**) ... “JAPAN” **EXE**

(**▼**) (**▼**) ... “FACT” **EXE**

(The message “Load Complete!” appears for about one second. After that, the display returns to normal.)



- You can also jump to a specific location in the sub-library by inputting a letter.

Inputting the letter “F” (**ALPHA** **F**), for example, causes the highlighting to jump to the first program name in the sub-library that starts with “F”.

- The message “Memory Full!” appears for about one second when there is not enough memory to store the program. Delete data you no longer need and try again.

- The screen shown to the right appears when a program with the same name as the one you are trying to load already exists in memory. Perform one of the following key operations when this happens.

```
[CROS11 ]
Already Exists
Overwrite?
F1:Yes
F6:No
AC:Cancel
YES NO
```

“YES” **F1** Replaces the existing program with the one you are loading.

“NO” **F6** Skips the program with the same name and continues with the load operation.

“AC” **AC** Aborts the load operation.

4. Press **AC** to return to the Program List screen.

Now you can run the program using the same procedures that you use to run your own programs.

Important!

- Executing some programs change the setting of your calculator. Be sure to check your calculator settings before executing a new program.
- Access the Web site at the following URL for detailed descriptions of each program does and how to use them:

http://world.casio.com/edu_e/

1 AUSTRALIA

1-1 Binomial Probability Distribution

Description : Produces a binomial probability distribution table.

File Name : BINPROB

1-2 Differential Equation Plot

Description : Draws the graph for any differential equation.

File Name : D.E.PLOT

* This program requires input of a formula in area Y1 of the Graph Mode.

1-3 Difference

Description : Finds the difference between each successive pair of values in a list (List 1) and stores the results in another list (List 2).

File Name : DIFFLIST

1-4 Differential Equation

Description : Draws the direction field diagram for any differential equation.

File Name : DIRECFLD

* This program requires input of a formula in area Y1 of the Graph Mode.

1-5 Mandelbrot

Description : Draws part of the Mandelbrot Set of fractals.

File Name : MANDLBRT

2 EA-100

2-1 Acceleration Meter

Description : Measures acceleration using a strip of aluminum that is bent by inertia.

Probe : Light Probe

File Name : ACCELA

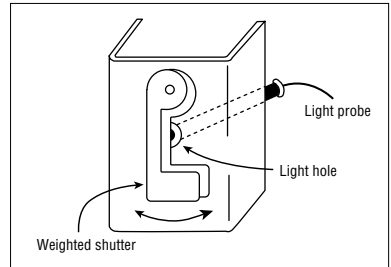

2-2 Measurement of Velocity and Acceleration Using a Bar Code

Description : Measures velocity and acceleration of a bar code passing in front of a light probe.

Probe : Light Probe

File Name : BAR V,A

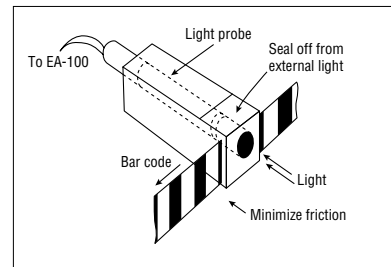

2-3 Breathing Capacity

Description : Measures breathing capacity in accordance with the speed of rotating blades.

Probe : Light Probe

File Name : BREATH

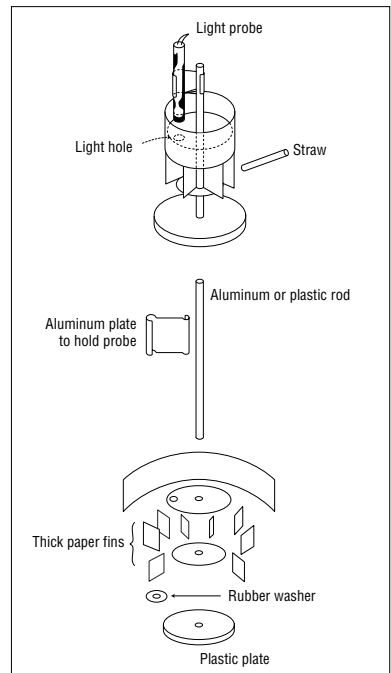

2-4 Digital Calipers

Description : Determines the distance between the two terminals of the calipers and produces it as a value on the display.

Probe : Voltage Probe

File Name : CALIPERS

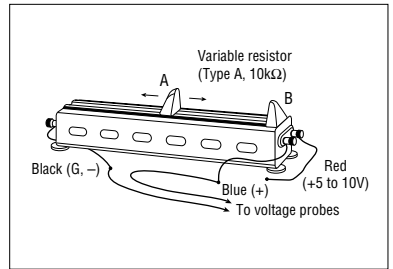

2-5 Display

Description : Plots temperature values measured by the EA-100 every second for one minute.

Probe : Temperature Probe

File Name : DISPLAY

2-6 Range Finder

Description : Measures the distance to an object in accordance with its distance and direction (angle) from two reference points.

Probe : Voltage Probe

File Name : DISTANCE

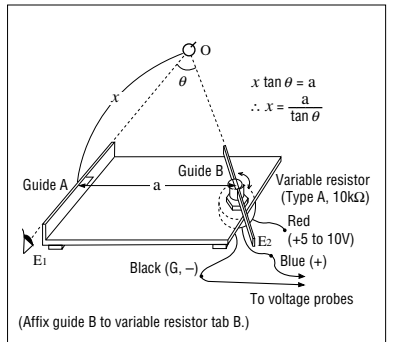

2-7 Electric Charge Curve of a Capacitor

Description : Shows changes in capacitor terminal voltage.

Probe : Voltage Probe

File Name : ELECHARG

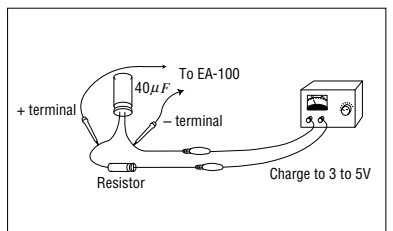

2-8 Electrical Potential Surface

Description : Measures and graphs the distribution of electric potential on the surface of a paper.

Probe : Voltage Probe

File Name : ELEPOTSF

* Change the set up screen's Fix setting to 1 before executing this program.

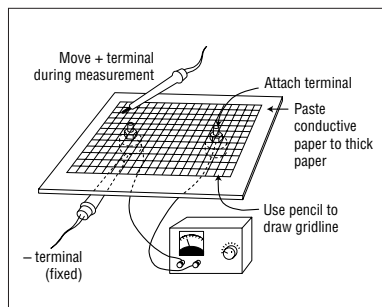

2-9 Free Fall of Ball and Repulsion Coefficient

Description : Graphs the height, speed, and changes in acceleration over time of a falling ball, and determines the repulsion coefficient from the height of the rebound.

Probe : Motion Detector

File Name : FREEFALL

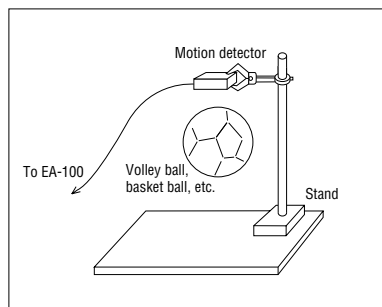

2-10 Distance from Light Source and Intensity

Description : Determines the relationship between the distance from a light source and illuminance.

Probes : Light Probe, Motion Detector

File Name : LIGHTINT

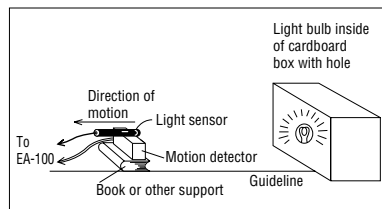

2-11 Lissajous Curves

Description : Produces a Lissajous curve using two sine waves for which a simple integral ratio is established.

Probes : Two Voltage Probes

File Name : LISSAJOU

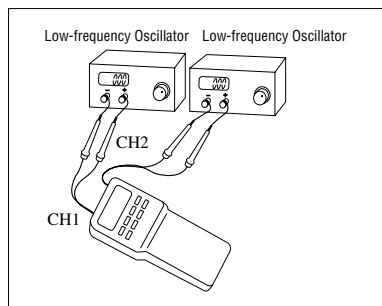

2-12 Melting Point of p-dichlorobenzene

Description : Determines the melting point of p-dichlorobenzene.

Probe : Temperature Probe

File Name : MELTPNT

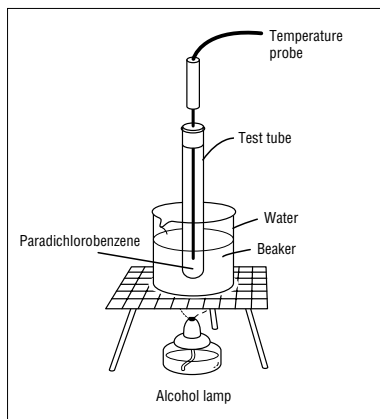

2-13 Simple Pendulum

Description : Produces a sine wave based on the movement of a simple pendulum.

Probe : Voltage Probe

File Name : PENDULUM

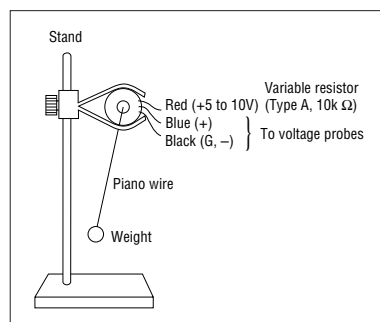

2-14 Measurement of pH with Colorimetric Density Meter

Description : Measures the acidity of rainwater.

Probe : Light Probe

File Name : PHMEASUR

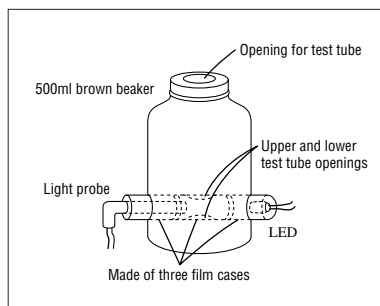

2-15 Measurement of Velocity and Acceleration from Three Points

Description : Measures velocity and acceleration of a moving object using three light probes placed along its path.

Probes : Three Light Probes

File Name : PNT V,A

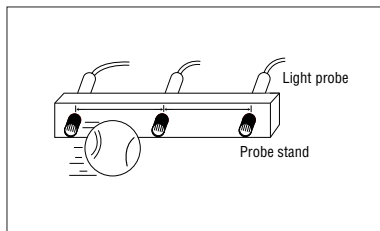

2-16 Temperature Titration

Description : Determines the neutralization point of an acid and an alkali (base).

Probe : Temperature Probe

File Name : TEMPTIT

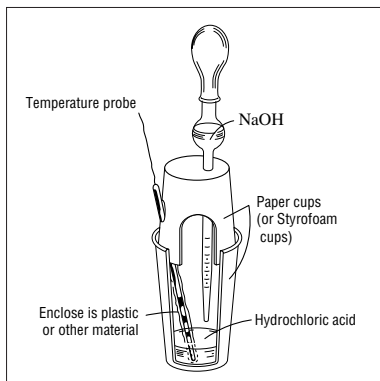

3 JAPAN

3-1 Chaos

Description : Draws chaos fractals.

The following programs are provided: CAOSI1, CAOSI2, CAOSI3, CAOSI4.

3-2 Greatest Common Measure

Description : Determines the greatest common measure for two integers (a and b) using Euclidean general division.

File Name : CMN

* See Chapter 22 of your User's Guide.

3-3 Prime Factor Analysis

Description : Produces prime factors of any positive integers.

File Name : FACT

3-4 Iterated Function System

Description : Draws fractals.

File Name : IFPLOT

* This program requires input of a matrix named Mat A.

3-5 Rotating a Figure

Description : Graphs rotation of any geometric figure.

File Name : ROTATE

* See Chapter 22 of your User's Guide.

3-6 Julia Set and Mandelbrot Set

Description : Draws Julia set and Mandelbrot set fractals.

The following programs are provided: SAFESET1, SAFESET2, SAFESET3, SAFESET4.

3-7 t -test

Description : Uses mean (sample mean) and sample standard deviation to obtain a t -test value.

File Name : T TEST

* See Chapter 22 of your User's Guide.

3-8 Circle and Tangents

Description : Obtains the slope and intercept from lines that are tangent to a circle.

File Name : TANGENT

* See Chapter 22 of your User's Guide.

3-9 Linear Transformation

Description : Performs rotation, parallel displacement, and magnification of a graphic image.

File Name : TRANSFER

4 SPAIN

4-1 Mandelbrot Fractal

Description : Draws built-in Mandelbrot set fractals.

The following programs are provided: NM-O-I, NM-O-I-B, NMAND2Z, NMAND3R.

5 U.S.A

5-1 Amortize

Description : Computes standard amortization calculations involved with annuities and loans: present value, future value, loan payments, and sinking fund payments.

File Name : AMORTIZE

5-2 Bond Calculation

Description : Performs bond calculations.

File Name : BONDMAIN

5-3 Powers of Complex Numbers

Description : Finds any power of a complex number.

File Name : CMPLXPWR

* Change the set up screen's Angle setting to Rad (radians) before executing this program.

5-4 Complex Roots

Description : Finds and displays the N complex solutions of $Z^N = c$, where c is any complex (or real) number and N is a positive integer.

File Name : CMPLXRT

* Change the set up screen's Angle setting to Rad (radians) before executing this program.

5-5 Double Integral

Description : Numerically approximates a double integral using the following formula:

$$\int_a^b \int_{f_4}^{f_5} f_6(x, y) dA = \sum f_6(\bar{x}_i, \bar{y}_i) \Delta x_i y_i$$

File Name : DBLINT

5-6 Euler's Method

Description : Plots the Euler's method solution of the following differential equation:

$$dy/dx = f_6(x, y)$$

File Name : EULER

5-7 Forecasting

Description : Uses exponential smoothing and the Holt-Winters forecasting model to predict future values from a chronological series of data.

File Name : FORECAST

5-8 Fundamental Theorem

Description : Numerically solves the differential equation $dy/dx = f_6(x)$, and plots the antiderivative $F(x) = F(a) + \int_a^x f_6(t)dt$.

File Name : FUNDTHM

5-9 Conic Section Graph

Description : Graphs $F(x, y)$ as a conic section graph.

File Name : IMPGRAPH

5-10 Linear Programming

Description : Solves a linear programming problem by the simplex method.

File Name : LINPROG

5-11 Prime or Composite Number

Description : Determines whether a number is prime or composite, and returns the lowest prime divisor for a composite number.

File Name : PRIME

5-12 Riemann Sum

Description : Approximates an integral by a Riemann sum:

$$\int_a^b f_6(x) dx = \sum f_6(\bar{x}_i) \Delta x$$

File Name : RIEMANN

5-13 Row Reduce Matrix A

Description : Row reduces Matrix A to reduce row echelon form.

File Name : ROWREDA

5-14 Slope Field

Description : Graphs the slope field of the following differential equation:

$$\frac{dy}{dx} = f_6(x, y)$$

File Name : SLOPEFLD

5-15 Triple Integral

Description : Numerically approximates a triple integral using the following formula:

$$\int_a^b \int_{f_2}^{f_3} \int_{f_4}^{f_5} f_6(x, y, z) dV = \sum f_6(\bar{x}_i, \bar{y}_i, \bar{z}_i) \Delta x_i \Delta y_i \Delta z_i$$

File Name : TRIPLINT

5-16 Time Value of Money

Description : Produces financial graphs based on data provided for any two of the following factors: future value (FV), payment amount (PMT), interest rate (I%), number of payments (n), and present value (PV).

File Name : TVMMAIN

6 UK

6-1 Fibonacci Sequence Generator

Description : Calculates the n -th number in the Fibonacci sequence.

File Name : FIBGEN

6-2 Triangle

Description : Displays the area and three angles of a triangle.

File Name : TRI

* Change the set up screen's Angle setting to Deg (degrees) before executing this program.

MEMO

CASIO®

CASIO COMPUTER CO., LTD.

6-2, Hon-machi 1-chome
Shibuya-ku, Tokyo 151-8543, Japan